

# Product data sheet

Specifications



## variable speed drive, Altivar Machine ATV320, 1.5kW, 380 to 500V, 3 phases, compact

ATV320U15N4C

**Product availability: Stock - Normally stocked in distribution facility**

### Main

Range of Product	Altivar Machine ATV320
Product or Component Type	Variable speed drive
Product Specific Application	Complex machines
Variant	Standard version
Format of the drive	Compact
Mounting Mode	Wall mount
Communication Port Protocol	Modbus serial CANopen
Option card	communication module, CANopen communication module, EtherCAT communication module, Profibus DP V1 communication module, PROFINET communication module, Ethernet Powerlink communication module, EtherNet/IP communication module, DeviceNet
[Us] rated supply voltage	380...500 V - 15...10 %
nominal output current	4.1 A
Motor power kW	1.5 kW heavy duty
Maximum Horse Power Rating	2 hp
EMC filter	Class C2 EMC filter integrated
IP degree of protection	IP20

### Complementary

Discrete input number	7
Discrete input type	STO safe torque off, 24 V DC1.5 kOhm DI1...DI6 logic inputs, 24 V DC 30 V) DI5 programmable as pulse input 0...30 kHz, 24 V DC 30 V)
Discrete input logic	Positive logic (source) Negative logic (sink)
Discrete output number	3
Discrete output type	Open collector DQ+ 0...1 kHz 30 V DC 100 mA Open collector DQ- 0...1 kHz 30 V DC 100 mA
Analogue input number	3
Analogue input type	A11 voltage 0...10 V DC 30 kOhm 10 bits A12 bipolar differential voltage +/- 10 V DC 30 kOhm 10 bits A13 current 0...20 mA (or 4-20 mA, x-20 mA, 20-x mA or other patterns by configuration) 250 Ohm 10 bits
Analogue output number	1

Price is "List Price" and may be subject to a trade discount – check with your local distributor or retailer for actual price.

<b>Analogue output type</b>	Software-configurable current AQ1 0...20 mA 800 Ohm 10 bits Software-configurable voltage AQ1 0...10 V DC 470 Ohm 10 bits
<b>Relay output type</b>	Configurable relay logic R1A 1 NO 100000 cycles Configurable relay logic R1B 1 NC 100000 cycles Configurable relay logic R1C Configurable relay logic R2A 1 NO 100000 cycles Configurable relay logic R2C
<b>Maximum switching current</b>	Relay output R1A, R1B, R1C resistive, cos phi = 1 3 A 250 V AC Relay output R1A, R1B, R1C resistive, cos phi = 1 3 A 30 V DC Relay output R1A, R1B, R1C, R2A, R2C inductive, cos phi = 0.4 7 ms 2 A 250 V AC Relay output R1A, R1B, R1C, R2A, R2C inductive, cos phi = 0.4 7 ms 2 A 30 V DC Relay output R2A, R2C resistive, cos phi = 1 5 A 250 V AC Relay output R2A, R2C resistive, cos phi = 1 5 A 30 V DC
<b>Minimum switching current</b>	Relay output R1A, R1B, R1C, R2A, R2C 5 mA 24 V DC
<b>Method of access</b>	Slave CANopen
<b>4 quadrant operation possible</b>	True
<b>Asynchronous motor control profile</b>	Voltage/frequency ratio, 5 points Flux vector control without sensor, standard Voltage/frequency ratio - Energy Saving, quadratic U/f Flux vector control without sensor - Energy Saving Voltage/frequency ratio, 2 points
<b>Synchronous motor control profile</b>	Vector control without sensor
<b>Maximum output frequency</b>	0.599 kHz
<b>Acceleration and deceleration ramps</b>	Linear U S CUS Ramp switching Acceleration/deceleration ramp adaptation Acceleration/deceleration automatic stop with DC injection
<b>Motor slip compensation</b>	Automatic whatever the load Adjustable 0...300 % Not available in voltage/frequency ratio (2 or 5 points)
<b>Switching frequency</b>	2...16 kHz adjustable 4...16 kHz with derating factor
<b>Nominal switching frequency</b>	4 kHz
<b>Braking to standstill</b>	By DC injection
<b>Brake chopper integrated</b>	True
<b>Line current</b>	6.4 A 380 V heavy duty) 4.9 A 500 V heavy duty)
<b>Maximum Input Current per Phase</b>	6.4 A
<b>Maximum output voltage</b>	500 V
<b>Apparent power</b>	4.2 kVA 500 V heavy duty)
<b>Network Frequency</b>	50-60 Hz
<b>Relative symmetric network frequency tolerance</b>	5 %
<b>Prospective line I<sub>sc</sub></b>	5 kA
<b>Base load current at high overload</b>	3.0 A
<b>Power dissipation in W</b>	Fan 56.0 W 380 V 4 kHz
<b>With safety function Safely Limited Speed (SLS)</b>	True
<b>With safety function Safe brake management (SBC/SBT)</b>	False
<b>With safety function Safe Operating Stop (SOS)</b>	False

With safety function Safe Position (SP)	False
With safety function Safe programmable logic	False
With safety function Safe Speed Monitor (SSM)	False
With safety function Safe Stop 1 (SS1)	True
With sft fct Safe Stop 2 (SS2)	False
With safety function Safe torque off (STO)	True
With safety function Safely Limited Position (SLP)	False
With safety function Safe Direction (SDI)	False
Protection type	Input phase breaks drive Overcurrent between output phases and earth drive Overheating protection drive Short-circuit between motor phases drive Thermal protection drive
Width	4.1 in (105.0 mm)
Height	5.6 in (142.0 mm)
Depth	6.2 in (158.0 mm)
Net Weight	2.9 lb(US) (1.3 kg)
Transient overtorque	170...200 % of nominal motor torque

## Environment

Operating position	Vertical +/- 10 degree
Product Certifications	CE ATEX NOM GOST EAC RCM KC
Marking	CE ATEX UL CSA EAC RCM
Standards	IEC 61800-5-1
Electromagnetic compatibility	Electrostatic discharge immunity test level 3 conforming to IEC 61000-4-2 Radiated radio-frequency electromagnetic field immunity test level 3 conforming to IEC 61000-4-3 Electrical fast transient/burst immunity test level 4 conforming to IEC 61000-4-4 1.2/50 $\mu$ s - 8/20 $\mu$ s surge immunity test level 3 conforming to IEC 61000-4-5 Conducted radio-frequency immunity test level 3 conforming to IEC 61000-4-6 Voltage dips and interruptions immunity test conforming to IEC 61000-4-11
Environmental class (during operation)	Class 3C3 according to IEC 60721-3-3 Class 3S2 according to IEC 60721-3-3
Maximum acceleration under shock impact (during operation)	150 m/s <sup>2</sup> at 11 ms
Maximum acceleration under vibrational stress (during operation)	10 m/s <sup>2</sup> at 13...200 Hz
Maximum deflection under vibratory load (during operation)	1.5 mm at 2...13 Hz
Permitted relative humidity (during operation)	Class 3K5 according to EN 60721-3
Volume of cooling air	4755.2 Gal/hr(US) (18.0 m <sup>3</sup> /h)
Overvoltage category	III

<b>Regulation loop</b>	Adjustable PID regulator
<b>Speed accuracy</b>	+/- 10 % of nominal slip 0.2 Tn to Tn
<b>Pollution degree</b>	2
<b>Ambient air transport temperature</b>	-13...158 °F (-25...70 °C)
<b>Ambient air temperature for operation</b>	14...122 °F (-10...50 °C) without derating 122...140 °F (50...60 °C) with derating factor
<b>Ambient Air Temperature for Storage</b>	-13...158 °F (-25...70 °C)

## Ordering and shipping details

<b>Category</b>	US1CP4B22152
<b>Discount Schedule</b>	CP4B
<b>GTIN</b>	3606480966750
<b>Returnability</b>	Yes
<b>Country of origin</b>	ID

## Packing Units

<b>Unit Type of Package 1</b>	PCE
<b>Nbr. of units in pkg.</b>	1
<b>Package 1 Height</b>	7.087 in (18.000 cm)
<b>Package 1 Width</b>	7.283 in (18.500 cm)
<b>Package 1 Length</b>	7.362 in (18.700 cm)
<b>Package weight(Lbs)</b>	3.732 lb(US) (1.693 kg)
<b>Unit Type of Package 2</b>	S06
<b>Number of Units in Package 2</b>	30
<b>Package 2 Height</b>	29.528 in (75.000 cm)
<b>Package 2 Width</b>	23.622 in (60.000 cm)
<b>Package 2 Length</b>	31.496 in (80.000 cm)
<b>Package 2 Weight</b>	141.890 lb(US) (64.360 kg)

## Contractual warranty

<b>Warranty (in months)</b>	18
-----------------------------	----



## Environmental Data

Schneider Electric aims to achieve Net Zero status by 2050 through supply chain partnerships, lower impact materials, and circularity via our ongoing “Use Better, Use Longer, Use Again” campaign to extend product lifetimes and recyclability.

[Environmental Data explained >](#)

[How we assess product sustainability >](#)



### Environmental footprint

Total lifecycle Carbon footprint	1 368 kg CO2 eq.
Environmental Disclosure	<a href="#">Product Environmental Profile</a>
Carbon footprint of the manufacturing phase [A1 to A3]	36 kg CO2 eq.
Carbon footprint of the distribution phase [A4]	0.3 kg CO2 eq.
Carbon footprint of the installation phase [A5]	0.3 kg CO2 eq.
Carbon footprint of the use phase [B2, B3, B4, B6]	1 328 kg CO2 eq.
Carbon footprint of the end-of-life phase [C1 to C4]	3 kg CO2 eq.

### Use Better



### Materials and Substances

Packaging made with recycled cardboard	Yes
Packaging without single use plastic	Yes
<a href="#">EU RoHS Directive</a>	Pro-active compliance (Product out of EU RoHS legal scope)
SCIP Number	C0283eca-ae5-4ec9-9f8c-c7e056d0a8d7
REACH Regulation	<a href="#">REACH Declaration</a>
California proposition 65	WARNING: This product can expose you to chemicals including: Lead and lead compounds, which is known to the State of California to cause cancer and birth defects or other reproductive harm. For more information go to <a href="http://www.P65Warnings.ca.gov">www.P65Warnings.ca.gov</a>



### Energy efficiency

Product contributes to saved and avoided emissions	Yes
----------------------------------------------------	-----

### Use Longer



### Lifetime extension

Repair	No
--------	----

### Use Again



### Repack and remanufacture

Recyclability potential, in %	59
Circularity Profile	<a href="#">End of Life Information</a>
Take-back	No

WEEE Label



The product must be disposed on European Union markets following specific waste collection and never end up in rubbish bins.

---

Dimensions Drawings

Dimensions

Right View, Front View and Front View with EMC Plate

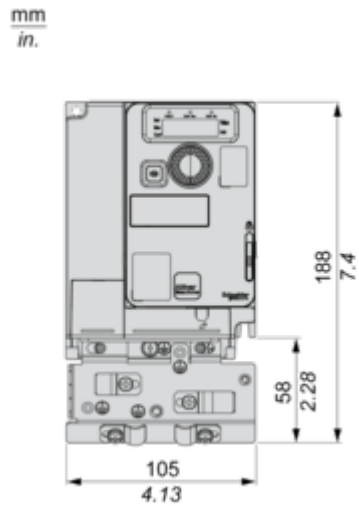
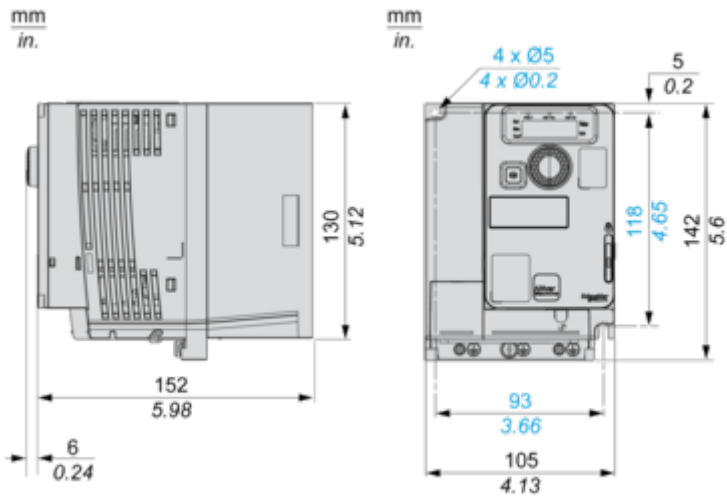

Mounting and Clearance

Mounting Types

---

Mounting Type A: Individual with Ventilation Cover

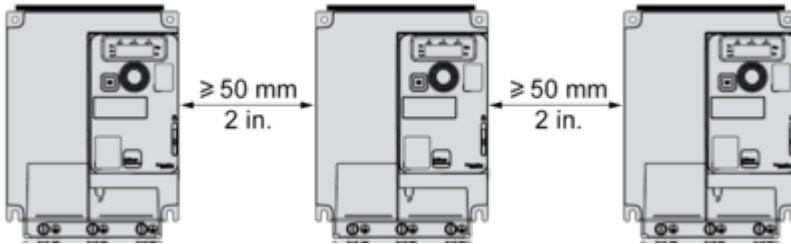

Only Possible at Ambient Temperature Less or Equal to 50 °C (122 °F)

Mounting Type B: Side by Side, Ventilation Cover Removed

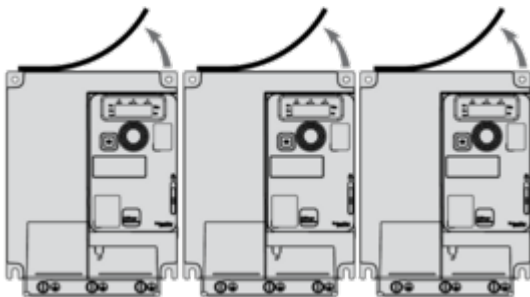

Mounting Type C: Individual, Ventilation Cover Removed

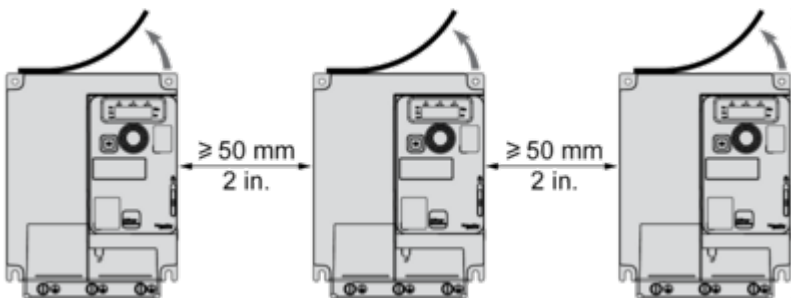

For Operation at Ambient Temperature Above 50 °C (122 °F)

Connections and Schema

Connection Diagrams

Single or Three-phase Power Supply - Diagram With Line Contactor

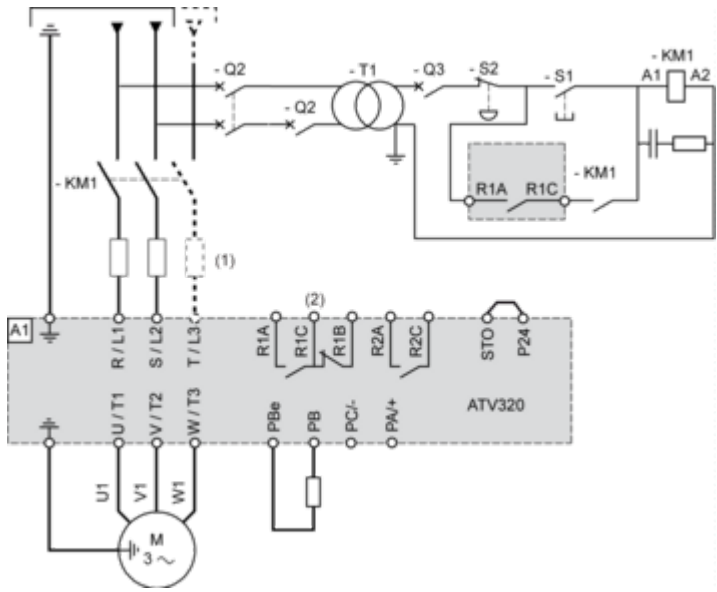

- (1) Line choke (if used)
- (2) Use relay output R1 set to operating state Fault to switch Off the product once an error is detected.

Single or Three-phase Power Supply - Diagram With Downstream Contactor

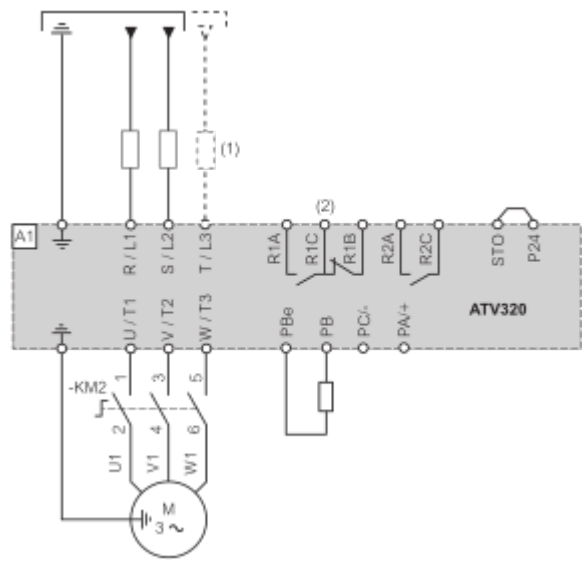

- (1) Line choke (if used)
- (2) Use relay output R1 set to operating state Fault to switch Off the product once an error is detected.



Digital Inputs Wiring

Switch Set to SRC (Source) Position Using the Output Power Supply for the Digital Inputs

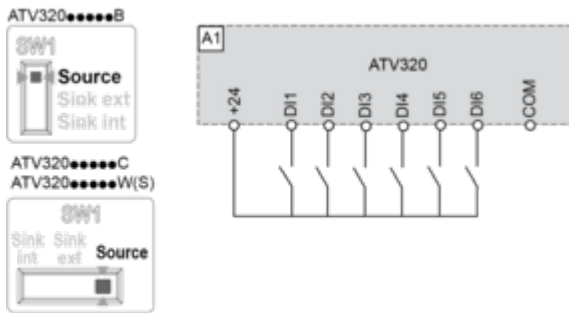

Switch Set to SRC (Source) Position and Use of an External Power Supply for the Digital Inputs

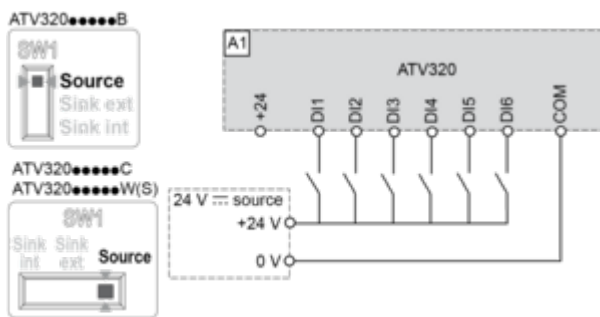

Switch Set to SK (Sink) Position Using the Output Power Supply for the Digital Inputs

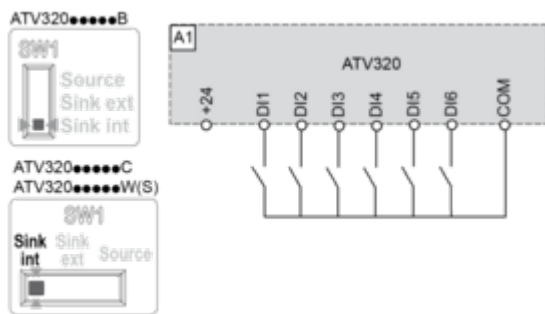

Switch Set to EXT Position Using an External Power Supply for the Digital Inputs

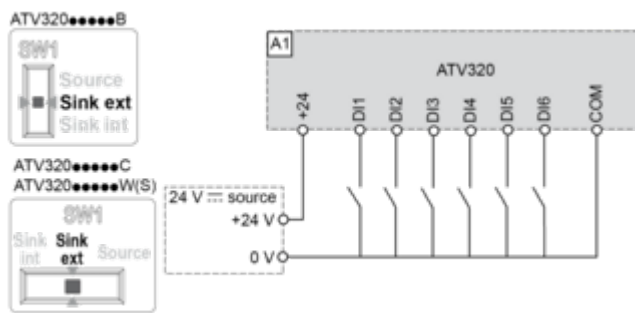

NOTE :

- STO input is also connected by default on a 24 Vdc terminal. If the external power supply is switched off, the function STO will be triggered.
- To avoid triggering the STO function when switching-on the product, the external power supply must be previously switched on.



Performance Curves

Derating Curves

---

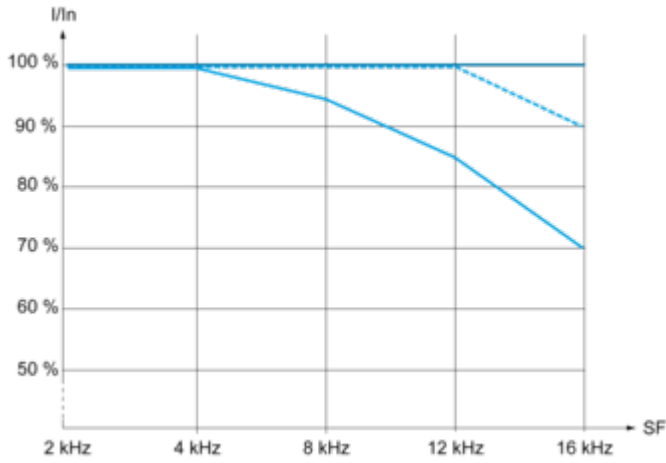

- 40 °C (104 °F) - Mounting type A, B and C
  - - - 50 °C (122 °F) - Mounting type A, B and C
  - 60 °C (140 °F) - Mounting type B and C
- In : Nominal Drive Current  
SF : Switching Frequency

Technical Illustration

Dimensions

---

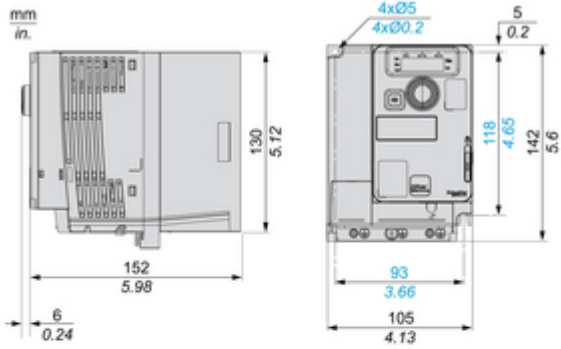

With EMC Plate

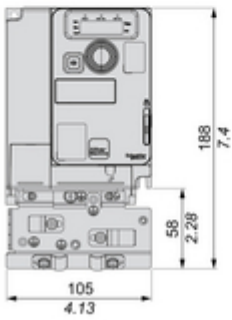

Image of product / Alternate images

Alternative

---





